

# Capacitive Torch Height Controller

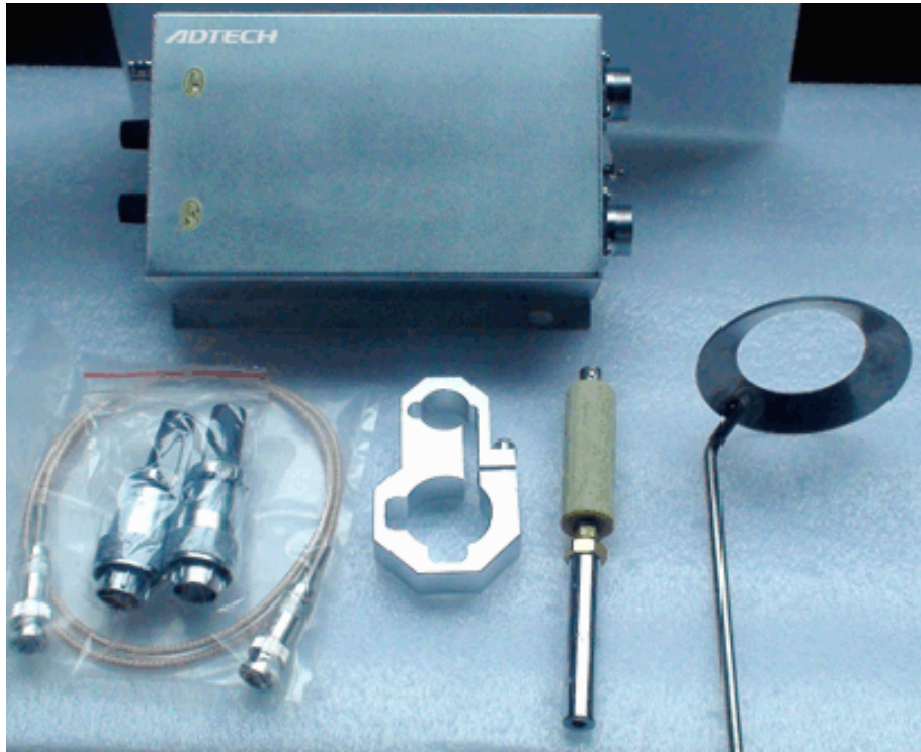

## HCB2001

ADTECH (Shenzhen) Technology Co.,LTD

**Read this manual fully before using the  
HCB2001**

**I 、 Brief Introduction**

Our design of Capacitive Torch Height Controller HCB2001 based on over 10 years practice and various requirements from domestic CNC cutting machine manufacturers.

HCB2001 is a closed-loop control system, with 4 parts: Position Signal Detection, Signal Process and Transform, Logic Control and Motor Drive, suitable for flame cutter, above water cutting below 100A plasma cutter, and laser cutting machine.

Figure 1 shows the working elements of HCB2001: The height signal detecting device adopts capacitive sensing loop, the detecting loop has to be insulated from cutting table and installed below cutting torch. Connect the detecting loop by side of torch via co-axis cable, to sense the height between cutting torch and the workpiece. HCB2001 sends out signal processed by circuit inside of it, to Logic Control circuit, and then continues with control signal to Motor Drive circuit, driving the lifter’s motor running accordingly to achieve the goal of adjusting height between torch head and work piece. Motor-driving is PWM.

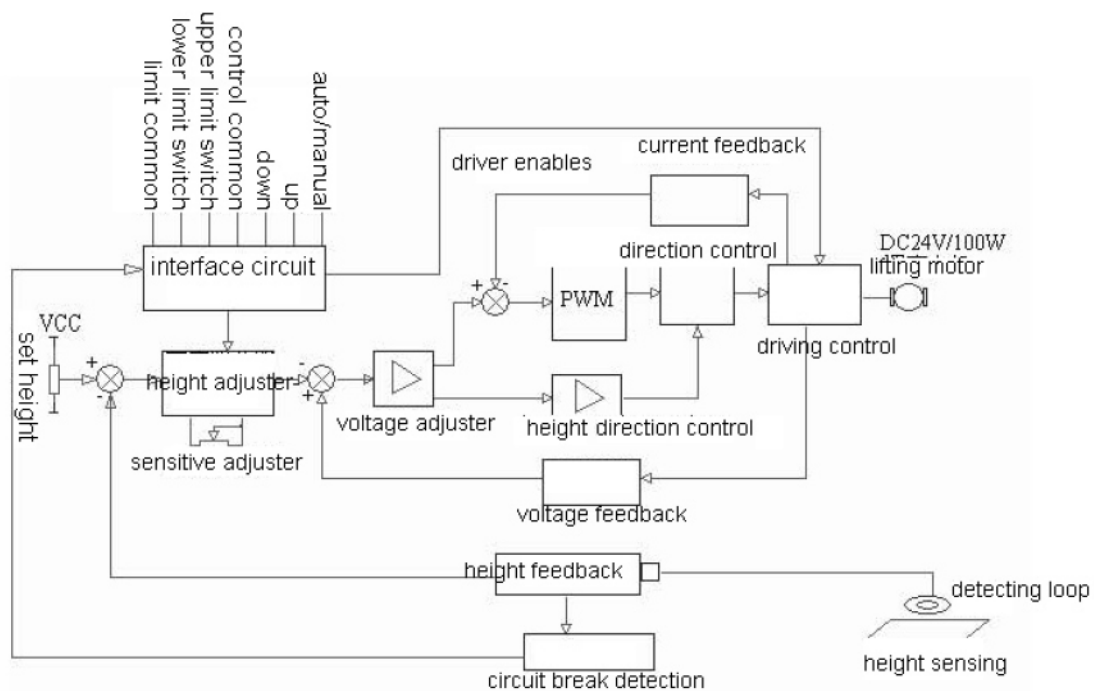

**Figure 1. working elements**

## I、 Key features

1. Analog circuit instead of SMD Tech on our THC, PWM driving mode, ensuring high reliability of THC.
2. **Circuit-broken protection.** On Auto Mode torch lift up automatically in the situation of HF disconnected, open circuit, short circuit, avoid crashing the torch.
3. Full-closed design, waterproof, dustproof, shockproof.
4. It adopts a method of modularization design, which is convenient for installation, commissioning and maintenance.
5. **Professional circuit-protection design greatly strengthens ability of anti-jamming.** Resister and Capacitor Absorb Circuit is adopted on power supply, preventing the interference of Surge Voltage and Harmonic Wave to THC effectively. Pressure Sensitive Circuit protection is adopted, avoiding the damage of over-voltage, and mis-connecting of power supply. Time-varying circuit is adopted, avoiding the damage of over-high voltage brought by workpiece under sensing (protection voltage>91v). Self-recovery circuit is adopted on signal-collecting part, at this part, the detecting circuit would break off if the current is over 1.3Ah.
6. Outside height setting, besides the HEIGHT button on operation panel, there's a R39 ⊕ at the back of control box, adjusting the height when the set height is not right.

## II、 Specification

Power Supply : AC24V+10%, 50Hz/60Hz

lifting motor : DC24V, DC motor

output current : 1A-4A

Working temperature :

HCB2001 -10 $\sim$ 60 $^{\circ}$ C,

High frequency coaxial-cable : -10 $\sim$ 200 $^{\circ}$ C,

Detective component/groupware : -10 $\sim$ 350 $^{\circ}$ C,

Accuracy :  $\pm$ 0.2mm

Adjustment range within accuracy : from the surface of work piece: 1mm —  
20mm

Max output power : 150W

Length of HF-cable:200mm $\sim$ 1500m

Size : Length\*Width\*Height : 200mm\*104mm\*50mm

Protection range of cutting-wire :There is no protection function when the length of HF-cable exceeds 1200mm.

### **III : Appearance and Installation**

#### 1、 Shape of HCB2001 :

Figure 2 : front panel view,

Figure 3 : back sight View,

Figure 4 : bottom view : installation size,

Figure 5: Back view

Figure 2 shows the shape of HCB2001.

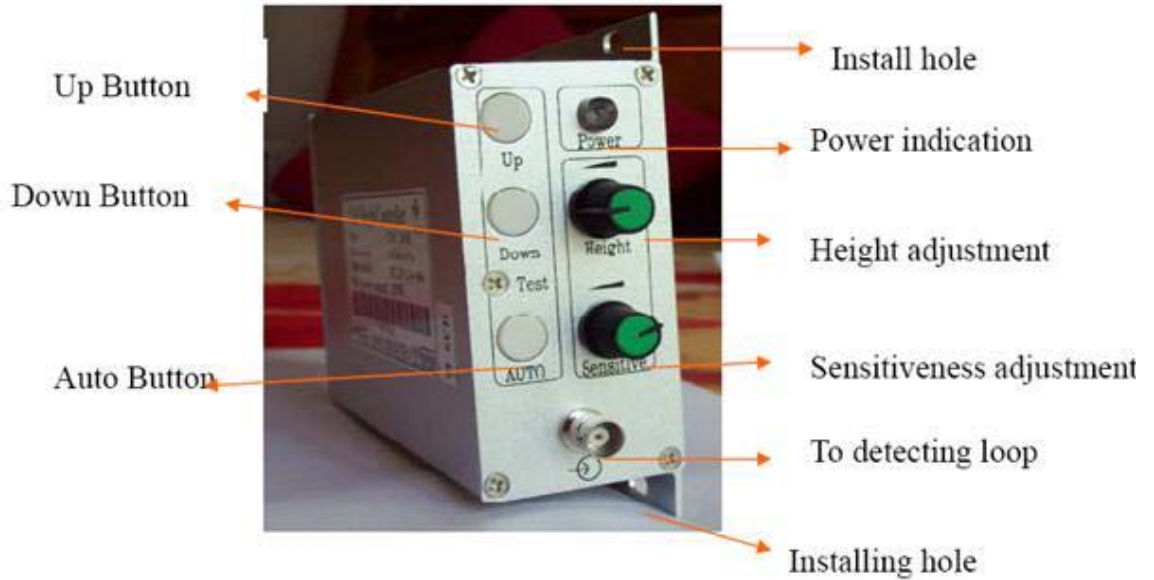

Figure 2: View of operation panel



Figure 3 : View of Connector

Figure 4 shows the installation size, the hole's size is 5x10mm, with 4mm screw to install. THC should be installed above and left side of cutting torch.

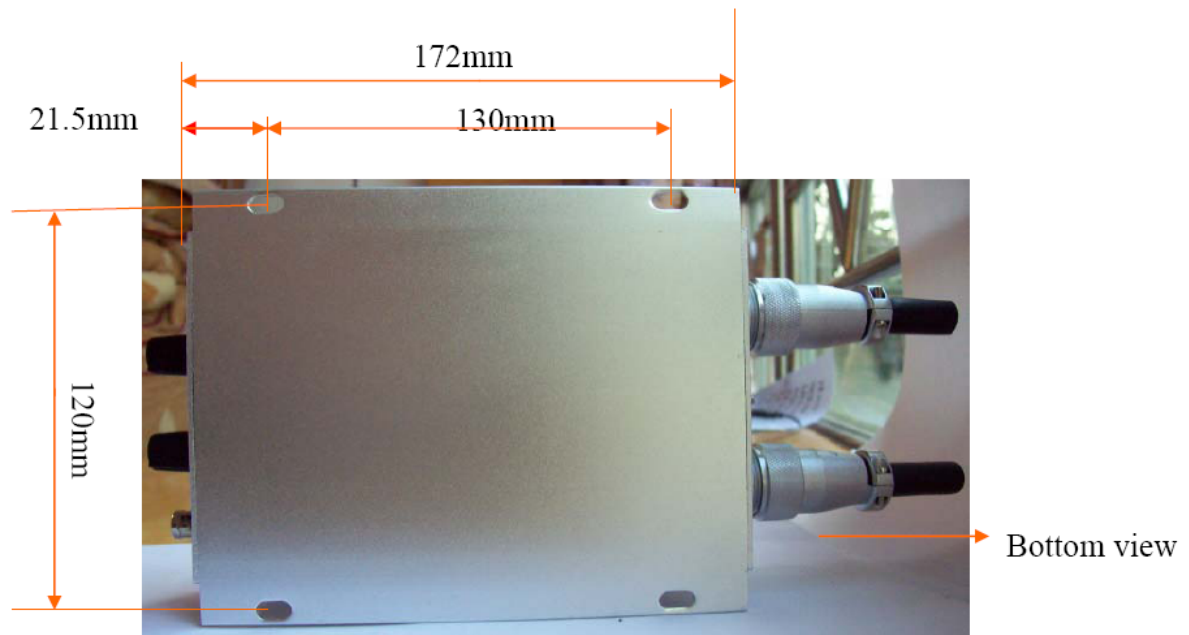

Figure 4 : Bottom view and installation size



Figure 5: Front view

- 2、 Installation of detecting loop: According to our years practice, detecting loop should be installed lower about 1~2mm than torch head to avoid the edge effect during cutting edge of workpiece, and it anti-bump more effectively, as

showed in Figure 6. While on plasma cutting, the detecting loop shall be installed little higher than the torch head, to avoid the effect of plasma arc voltage.

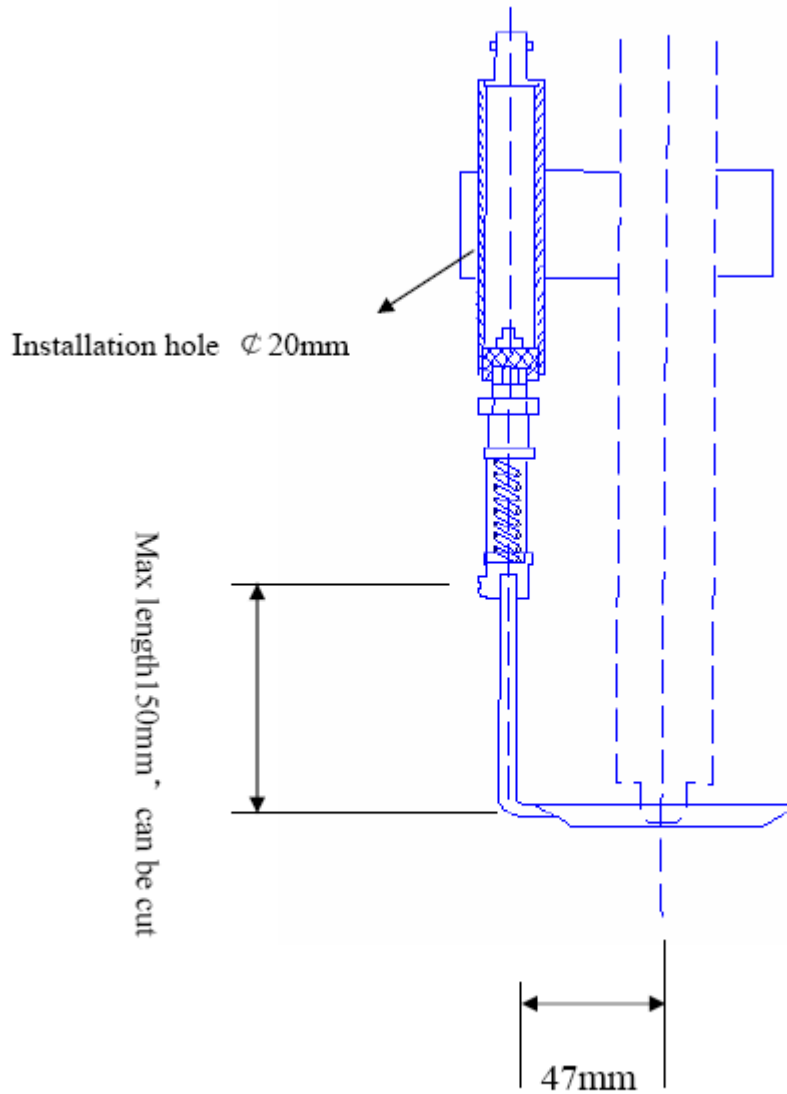

Figure 6 : Detecting loop installation.

**IV : Components**

As the Figure 7 shows the CHC consists of three parts: HCB2001, detecting loop and loop groupware.



Fixture,  
offered free  
with THC

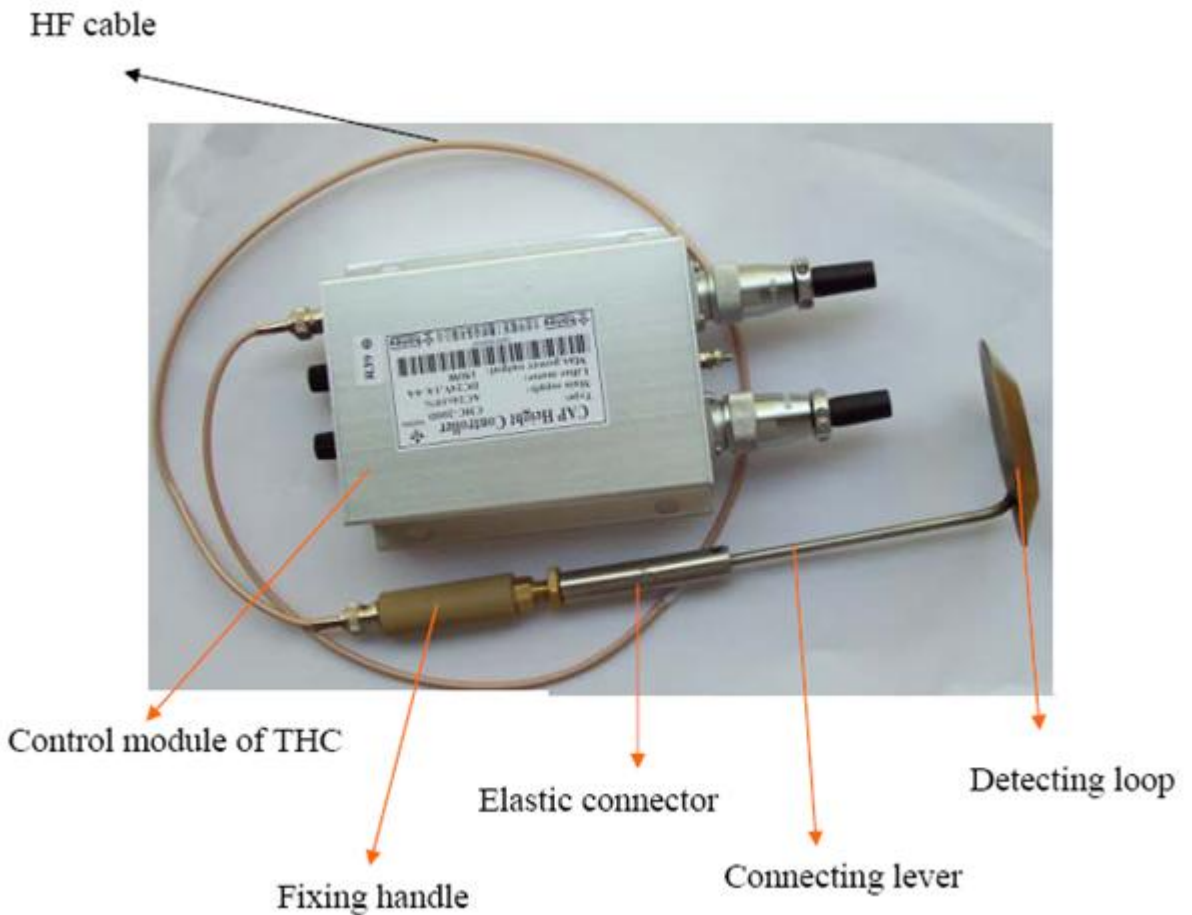

HF cable

Control module of THC

Fixing handle

Elastic connector

Connecting lever

Detecting loop

Figure 7: HCB2001 Assembly

**V : Instruction of Operation Panel Function**

1、 The operation panel of HCB2001 as Figure 8 shows:

**Power indication:**

**Auto Button:**

Press the AUTO button, the HCB2001 is always on Auto Mode, no matter there is a auto signal from outside or not. Then the demanded height can be set via Height button, (keep pressing AUTO during this process). It greatly simplify the setting of Auto Height Position.

During cutting, THC needs to work on Auto Mode and it should be controlled by CNC, having nothing to do with this Auto button

**Up/Down Button:**

It is active on any mode. Priority is always given to Manual mode.

For UP and Down, priority's given to UP. In case HF gets problem, it's always on UP mode, so the Down doesn't work.

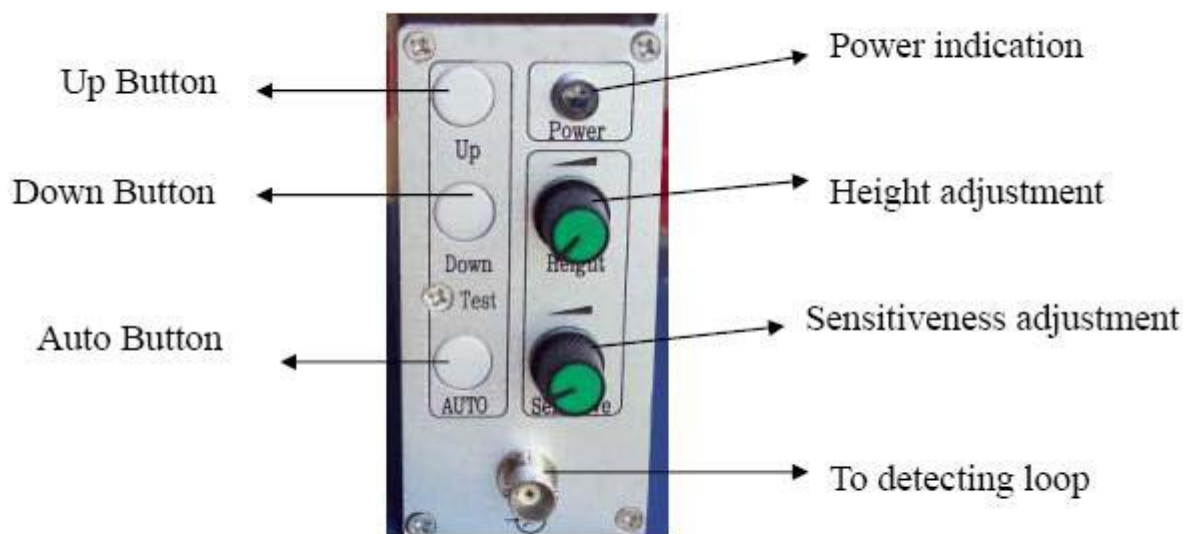

Figure 8 : View of operation panel

**Height:**

It is used to adjust cutting torch's height during Auto Mode. Height increases when it is turned clockwise. At the first commissioning, turn clockwise maximum to reach the highest height.

**Sensitiveness:**

On Auto Mode, the Sensitiveness increases when it is turned clockwise.

Detecting loop connects the socket: One end of HF Cable link with the socket, the other end link with the probe through loop groupware.

**2、 Back of HCB2001:**

Aviation socket:



Connect CNC

Connect Lift motor and limit  
switch

Figure 9: Back of HCB2001

**3、 Spec of detecting loop: Figure 10**

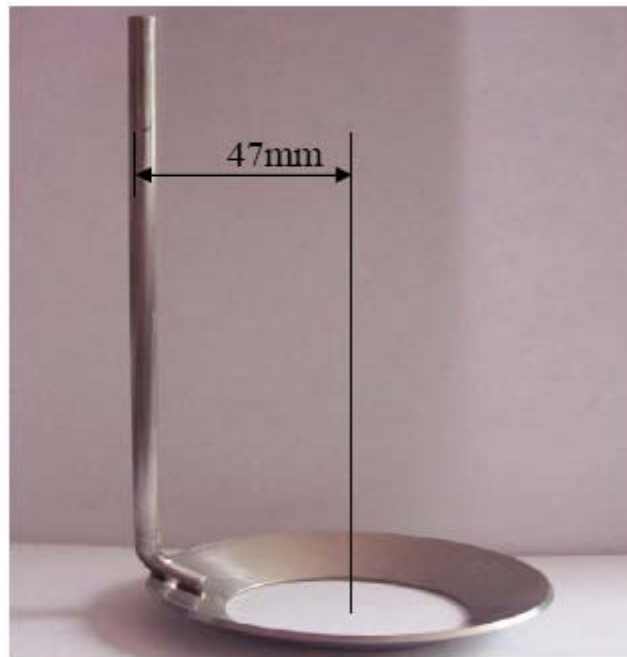

Figure 10 : Detecting loop

HF Cable: The length of the cable can be chosen from 500mm to 1500mm requested by clients as Figure 11 shows:



Figure 11 : HF cable



Figure 12: Installation Handle



Figure 13 : Elastic Connector

## **VI、 Interface Circuit**

### **1、 Control circuit of HCB2001**

The HCB2001 consists of 2 pieces PCB, the control circuit as Figure 14 shows:

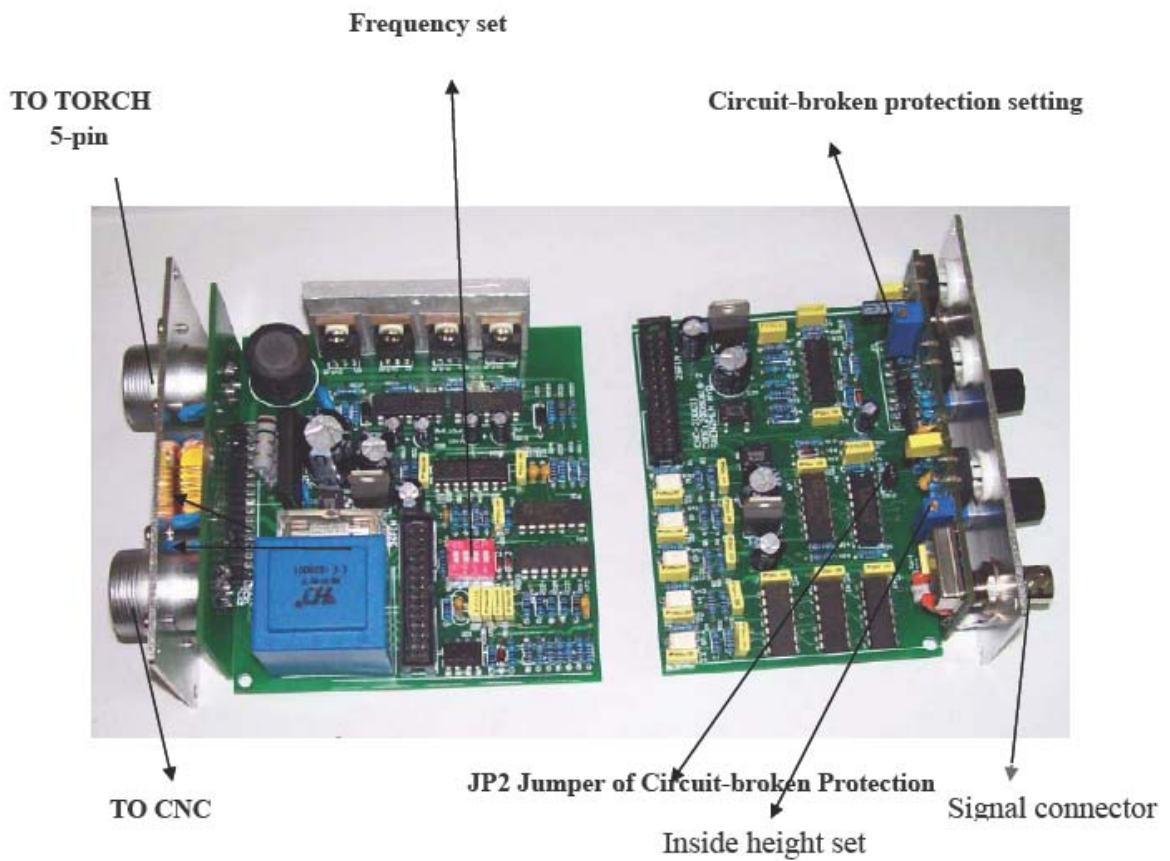

Figure 14 : Control PCB

THC consists of following connecting ports:  
 Connect with CNC (4Pins JP3 socket) :

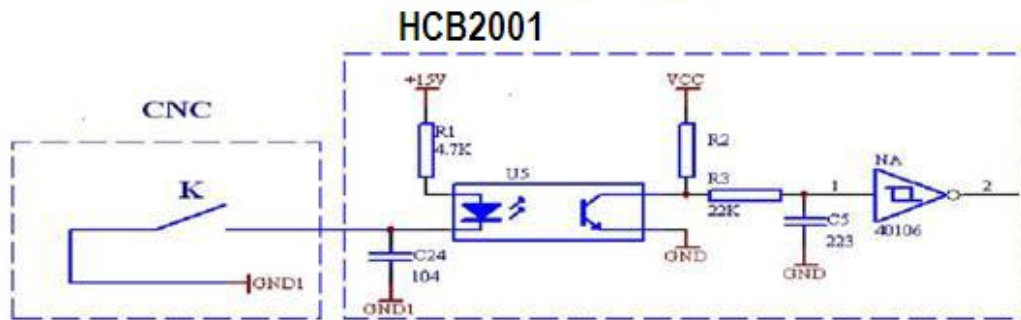

Figure 15: Switch connecting mode ↵

Note : It is on Auto Mode when the switch is closed.

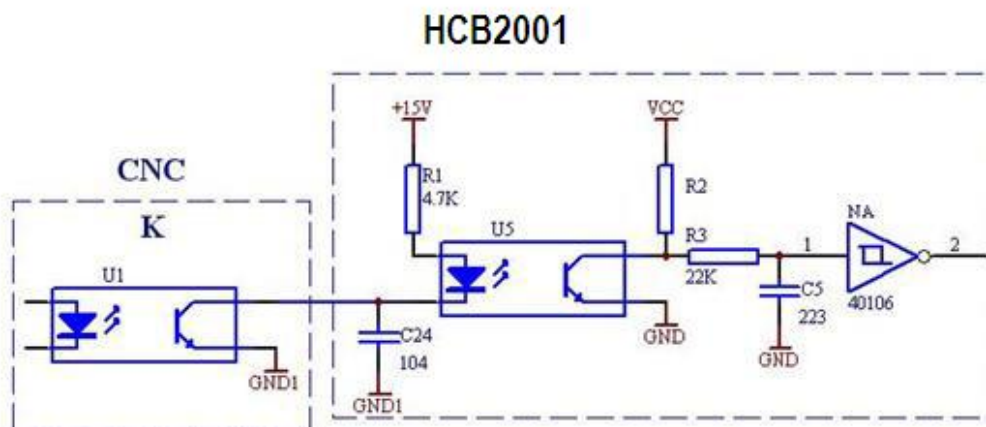

Figure 16: Optical-isolation ↵

Connecting To Torch ↵

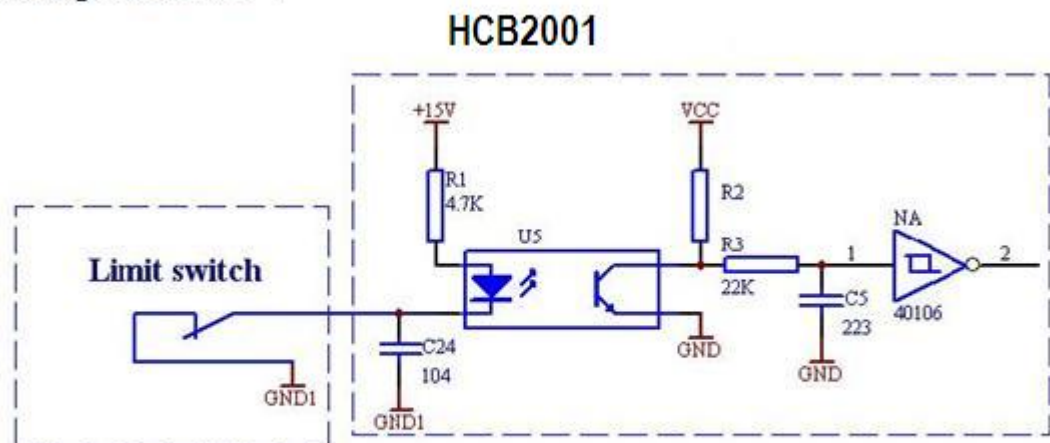

Figure 17: Limit Switch mode ↵

**HCB2001**

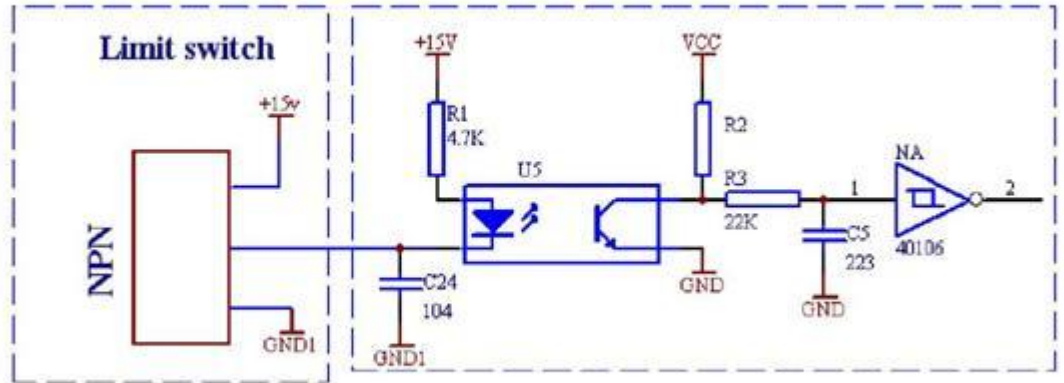

Figure 17: Limit Switch mode.

MOTOR Drive: S13 and S12 is the output of Motor Drive.

The voltage of MOTOR is DC24V.

Motor driving elements as Figure 19 shows:

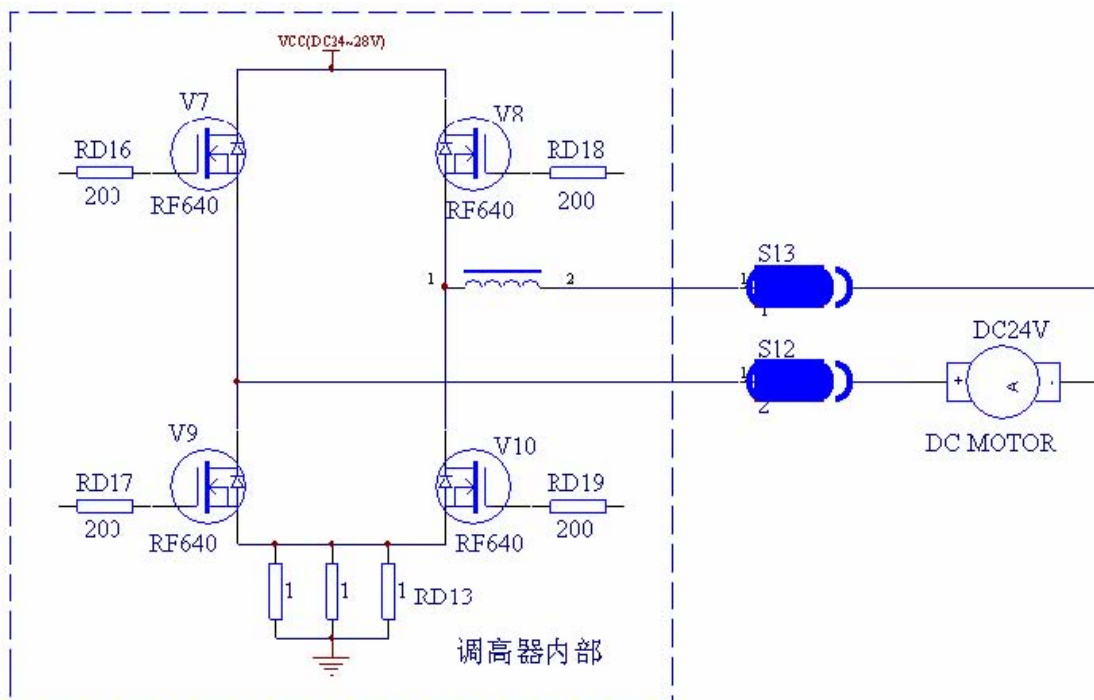

Figure 19: MOTOR drive

It adopts PWM mode, the frequency of PWM ranges from 18khz and 36 khz, the

switch operation is made by SP2-1 on the control panel. As Figure 20 shows:

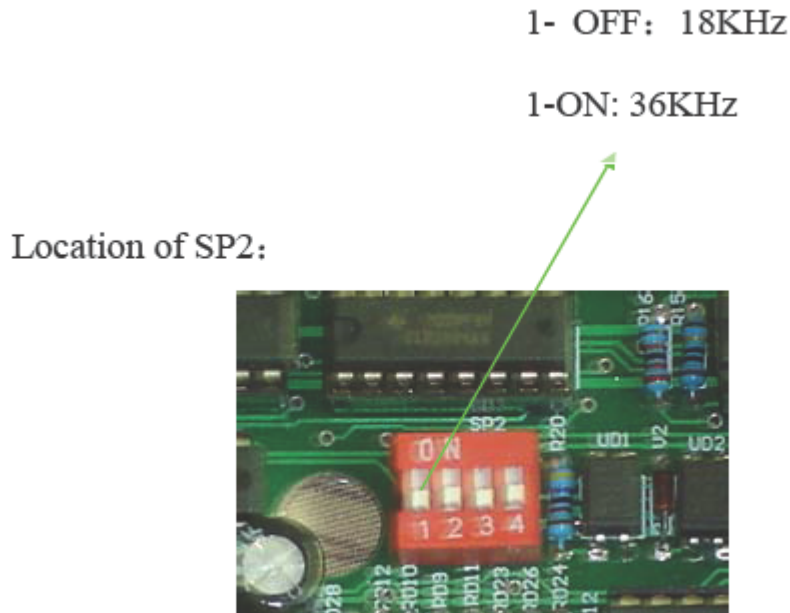

Figure 20: PWM frequency switch

## VII : Connection Instruction

- 1、 Figure 21 shows the connection of control PCB's aviation socket.

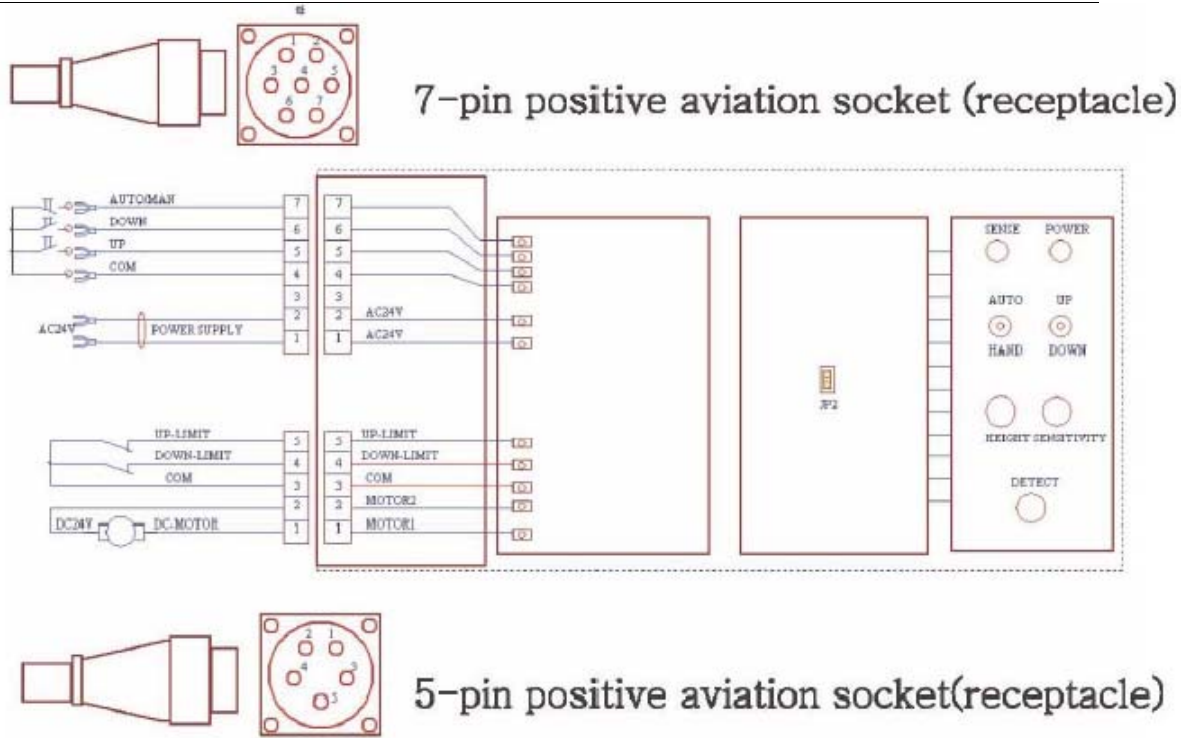

Figure 21 : Control PCB –Connection of aviation socket

**2、 Connection Of CNC and THC (X1-CNC )**

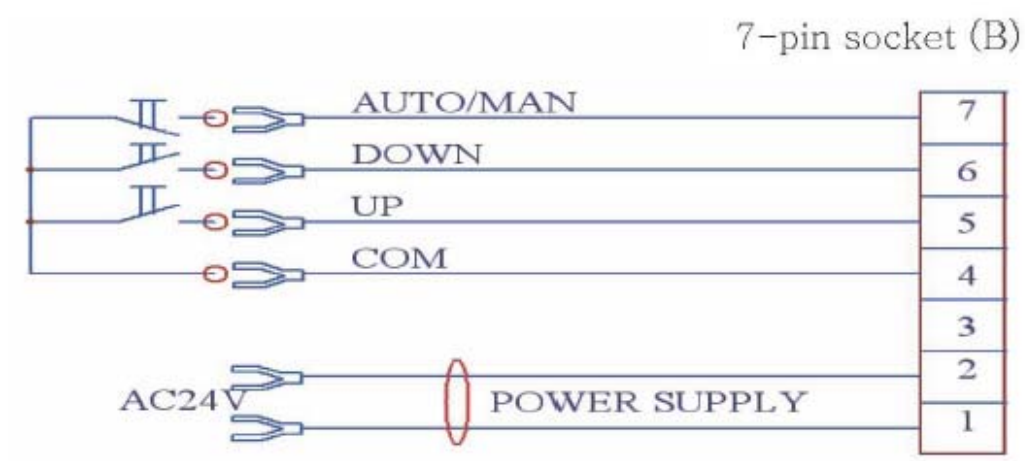

Figure 22: Connection of CNC

**3、 Connection of Down/Up limit and motor(X2-TORCH)**

5Pin Socket (plug)

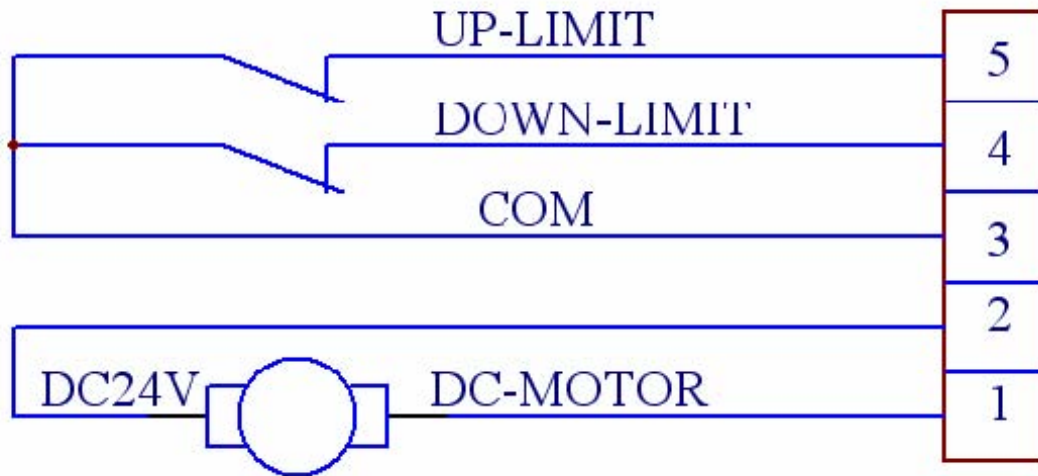

Figure 23: Connection of Down/Up limited and motor

### VIII、 Commissioning.

1. Up/Down connects with GND, motor moves up and down at maximum speed.

Auto/Manual connects with GND, THC is on Auto Mode. When it is open, the manual mode is active. In this situation, if the detecting loop is not connected with THC and THC is under circuit-broken protection function, cutting torch would keep lifting up. If loop is connected with THC, the cutting torch shall stop at a height via adjusting the **Height** button.

On Auto Mode, the height of cutting torch is under control of **Height** button. At first commission, always turn clockwise maximum to get the highest height, then turn anti-clockwise, the height decreases. In case over adjusted, cutting torch touches the workpiece; motor will be on a shocking-state.

The system always drives motor to make detecting loop close to the balance position (it stops when loop is around the balance position, 0.2m lower or higher). The closer, the more slowly the motor runs.

Auto sensitivity meets the request of system when loop is 5—20mm away from workpiece.

2. As the difference of cutting torch, it might be hard to find the balance position in all range of Height adjusting. In this situation, DO NOT open the control box, just debug the ⊕ of R39 + ⊕ at the back of HCB2001,

As follow,

2.1. Ensure the Auto Height Control is Enabled, or press the AUTO button and hold on.

2.2 Turn the Height button clockwise maximum, then the motor will drive loop move, and turn Height button left and right, the balance position should be found. Still negative, please try follow ways,

A.lift cutting torch to at least 50mm height, then put it on manual mode.

B. if previous Auto Height too low, then turn the R39 clockwise, the height will increase. If previous Auto Height too high then turns anti-clockwise, the height will decrease. DO NOT open control box, and DO NOT damage the R39 during debug, every time just turn 1/4 round, and record the direction.

C. Press AUTO button and hold on, or turn on the Auto Mode of CNC, adjust the HEIGHT button of THC, cutting torch shall stop at a position. And the adjusting arrange changed much.

3. On Auto Mode, turn the HEIGHT button clockwise, the probe shall lift up, anti-clockwise, it lifts down.

**Note: Our THC's already passed well commissioning. Do not change the setting unnecessarily, especially the adjustable resistance inside like R39.**

Follow are the info of the adjustable resistances.

R39---1K----Auto height setting

R47---20K----Setting the position under circuit-broken protection(HF part) .

Free Offer.....

To make users' job much easier, we designed a Fixture fixing torch and detecting loop, made of Aluminum Alloy. From May 10th, we offer it with HCB2001 on Free Base.

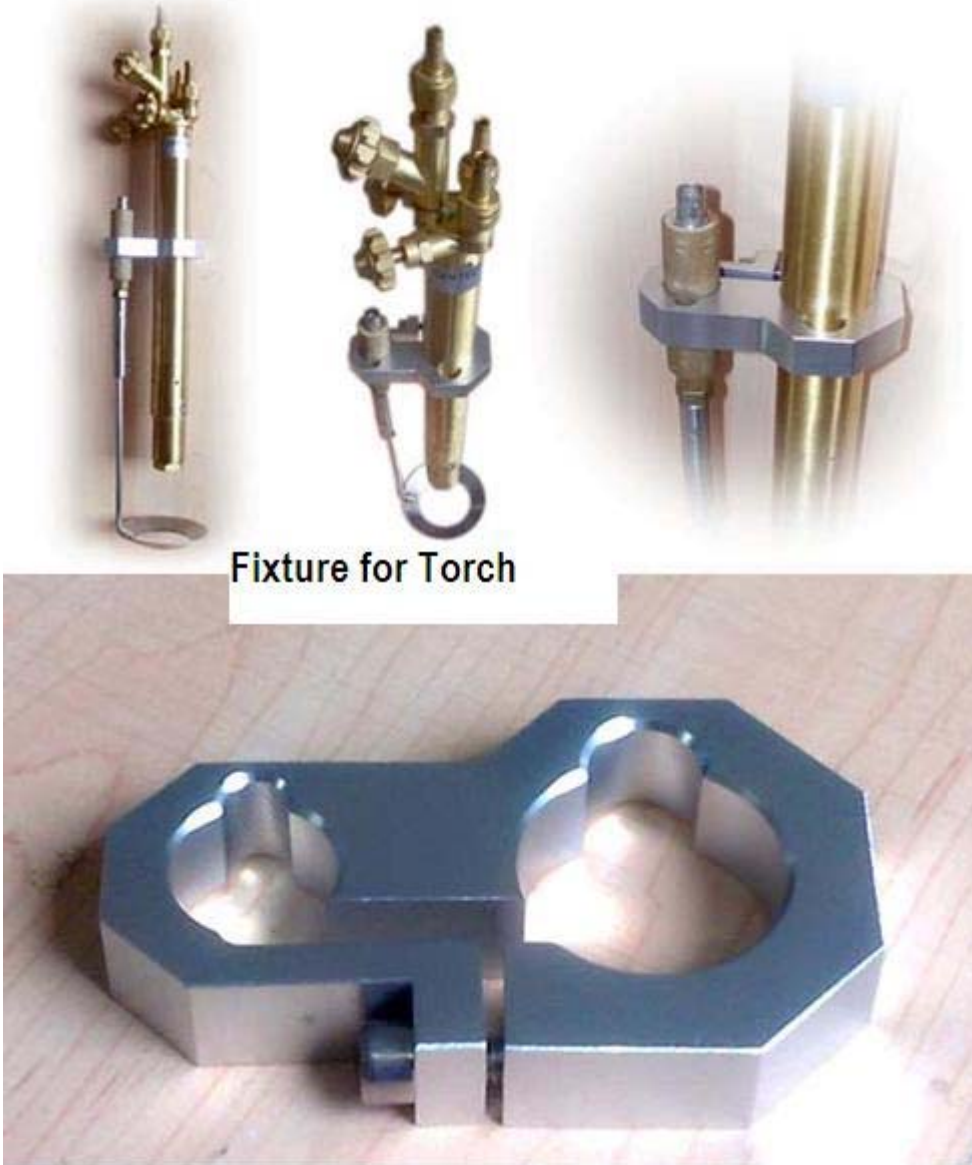

Fixture for Torch